

Part #501071-001

# Product Manual:

Model #DBF-43A  
Davit Base - Folding



  
**PELSUE**<sup>®</sup>  
*ISO 9001 Certified*

T.A. Pelsue Company  
2500 South Tejon Street  
Englewood, Colorado, USA 80110  
Tel. 800-525-8460 or 303-936-7432  
Fax. 303-934-5581  
Internet: [www.pelsue.com](http://www.pelsue.com)  
Email: [sales@pelsue.com](mailto:sales@pelsue.com)



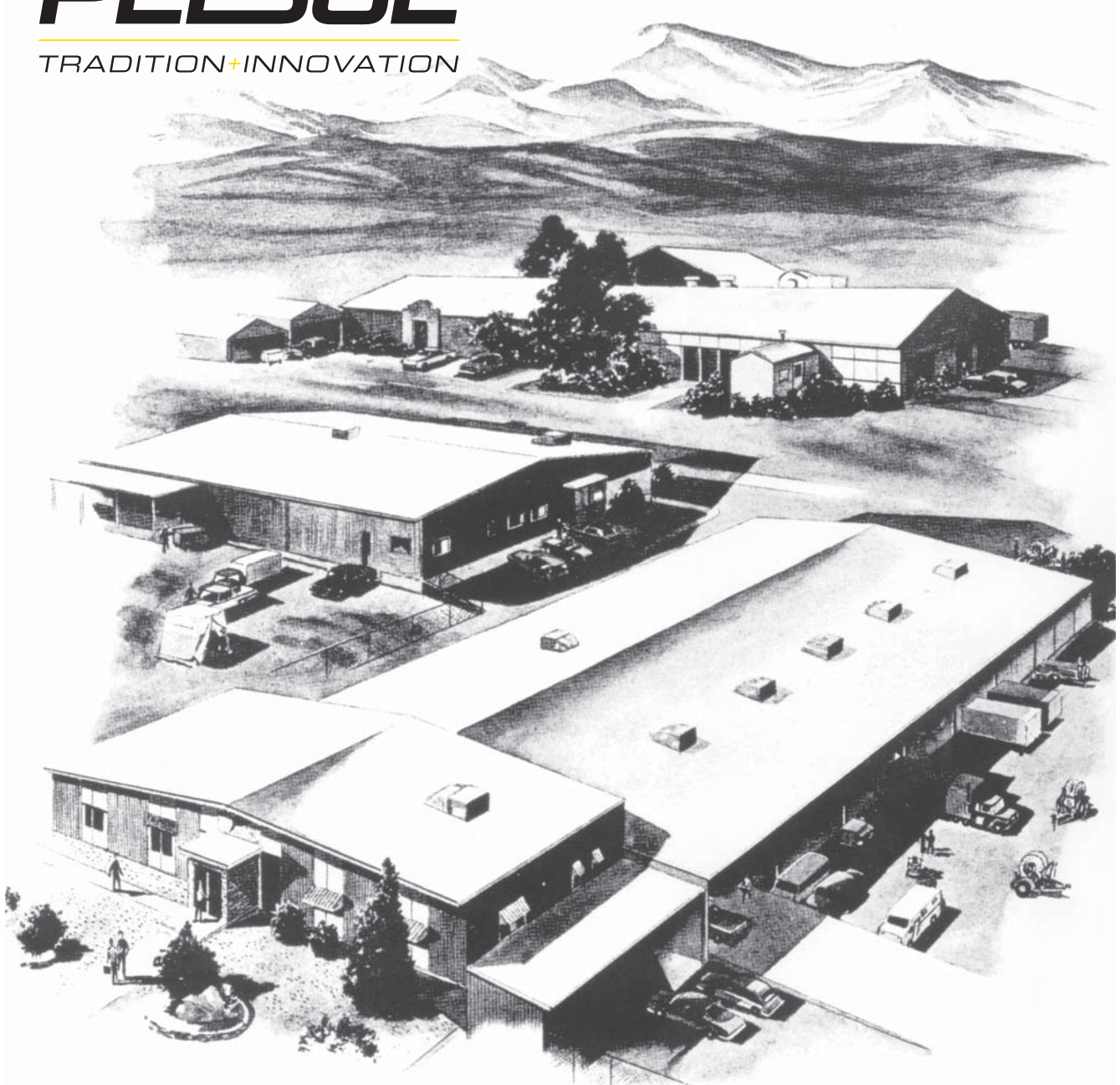

**S**ince our inception in 1963 – the T.A. Pelsue Company has designed and manufactured high quality equipment to improve the personnel efficiency and working conditions in various underground, confined, and outdoor areas.

Founded by T. Allen Pelsue, the company has established a continuing reputation for excellence in the production of fine products for a broad spectrum of industry throughout the world.

Now, in our second generation of family direction, continued commitment to innovation and quality makes Pelsue a leading source of equipment for many types of confined spaces. We specialize in safety, retrieval, fall arrest, ventilation, cable placing, splicing, and maintenance nationally and abroad. With more than 70,000 square feet of facilities available, Pelsue continues the dedication that has made us pre-eminent in this field.

# Table of Contents

---

<b>Section</b>	<b>Description</b>	<b>Page #</b>
<b>1.0</b>	<b>General Information</b>	<b>5</b>
1.1	Quality Policy	
1.2	Pelsue Product Warranty	
<b>2.0</b>	<b>Introduction &amp; Product Information</b>	<b>7</b>
2.1	Serial Number	
<b>3.0</b>	<b>Configuration &amp; Assembly</b>	<b>8</b>
3.1	Label Locations	
<b>4.0</b>	<b>Safety</b>	<b>10</b>
4.1	Warning Statement	
4.2	Safety Alert Symbol	
4.3	General Safety Information	
4.4	Operating Safety	
4.5	Maintenance Safety	
4.6	New Operator Safety Information	
<b>5.0</b>	<b>Product Operation</b>	<b>13</b>
5.1	Product Description & Capabilities	
5.2	Product Installation & Set-Up	
<b>6.0</b>	<b>Maintenance &amp; Inspection</b>	<b>16</b>
6.1	Maintenance	
6.2	Inspection	
6.3	Inspection Log	
<b>7.0</b>	<b>Storage</b>	<b>21</b>
<b>8.0</b>	<b>Contact Information</b>	<b>21</b>

### T.A. Pelsue Company

#### Quality Policy

OUR GOAL IS THE PURSUIT OF NEVER-ENDING IMPROVEMENT IN PRODUCT QUALITY AND BUSINESS SYSTEMS.

METHODS TO BE EMPLOYED IN ATTAINING THIS GOAL WILL INCLUDE NEW PRODUCT QUALITY PLANNING, EMPLOYEE TRAINING, AND UTILIZATION OF EMPLOYEE INVOLVEMENT GROUPS TO SOLVE PROBLEMS.

IN AN INCREASINGLY COMPETITIVE MARKETPLACE, ENSURING CUSTOMER SATISFACTION IS ONE OF THE DIFFERENTIATORS THAT SETS YOU APART FROM THE PACK AND YIELDS A COMPETITIVE ADVANTAGE.

THEREFORE, WE WILL SUPPORT TOTAL CUSTOMER SATISFACTION BY IMPLEMENTING THE **ISO 9001 QUALITY SYSTEM** AND PROVIDING THE NECESSARY ATMOSPHERE AND TRAINING TO NURTURE THIS CONCEPT THROUGHOUT OUR ORGANIZATION.

WE WILL MAKE EVERY BUSINESS DECISION AS THOUGH THE QUALITY OF THE PART OR SERVICE PROVIDED WAS DESTINED FOR OUR OWN OR OUR FAMILY'S USE. WE WILL ALWAYS THINK **QUALITY FIRST**.

EVERY T.A. PELSUE COMPANY EMPLOYEE IS EXPECTED TO COMMIT TO THIS PHILOSOPHY IN THE PERFORMANCE OF HIS OR HER DAILY TASKS.

**QUALITY FIRST!**

T.A. PELSUE COMPANY SENIOR MANAGEMENT TEAM

## 1.2 - Pelsue Product Warranty

---

Pelsue products are designed and engineered to perform as stated in published specifications. Quality materials and workmanship are used in the manufacture of this product. With regular maintenance and proper care, Pelsue equipment provides many trouble free hours of operation.

The T.A. Pelsue Company warrants to the buyer that the Hoist Product furnished will conform to specifications and will be free from defects in material and workmanship from the date of shipment to the original buyer, for a period of 3 months (90 days). In the event of failure of any components of a Pelsue product within the warranty period, service must be pre-approved by the T.A. Pelsue Company, and service must be performed by the T.A. Pelsue Parts and Service Department in Englewood, Colorado, or at the option of the T.A. Pelsue Company, service may be performed at any designated service center, which may include any authorized service center for the component manufacturer. Unauthorized repairs will not be covered by this warranty.

Damage or failure due to misuse, mishandling, or unauthorized modifications will not be covered by this warranty. Unless otherwise agreed, the T.A. Pelsue Company shall repair or replace the defective components within (30) calendar days of notice of failure. T.A. Pelsue Company's obligation hereunder, shall be limited to the repair or replacement of the product or component as set forth above and shall not include any liability whatsoever for damages caused by such failure, including, but not limited to consequential or incidental damages flowing from use or lack of use of product.

Any replacement, repair, modification, installation, or other service performed by the T.A. Pelsue Company shall be warranted by the remainder of the unexpired period of the warranty, or for a period of (90) calendar days, whichever is longer.

All materials or parts returned for credit or warranty shall be returned only with prior approval, and will be subject to factory inspection before credit is allowed. Parts claimed defective will be replaced upon request and will be invoiced as purchased, subject to credit when the parts claimed to be defective have been received and examined by the factory.

This warranty is expressly in lieu of all other warranties expressed or implied, including any warranties of merchantability or warranties of fitness for any particular use and all other obligations or liabilities in connection with the sale of this equipment.

T.A. Pelsue Company, 2500 South Tejon Street, Englewood, Colorado 80110, 800-525-8460

## 2.0 - Introduction & Product Information

Congratulations on your choice of a **Pelsue Model #DBF-43A Folding Davit Base** to compliment your confined space entry/retrieval operation. This equipment has been designed and manufactured to exceed confined space requirements and regulations in order to meet the needs of the discriminating operator for the efficient and safe entry or retrieval of personnel from a confined space.

Safe, efficient and trouble-free operation and maintenance of the system requires that anyone who will be operating, maintaining, or inspecting the equipment, read, understand and follow all the operation, safety, maintenance, and inspection instructions contained within this manual. This manual covers the Pelsue Model #DBF-43A Folding Davit Base. Use the Table of Contents as a guide to find specific information.

Keep this manual handy for frequent reference and to pass on to new operators. Establish a regular training program for experienced and new operators per this manual. Establish a regular maintenance and inspection program to keep the equipment in top condition.

**! WARNING**

This product is a part of a man rated confined space entry/retrieval system. The user must read, understand and follow the instructions contained in this manual for each component or total system before using this equipment. Establish an appropriate training, maintenance and inspection program for your people and the equipment. Failure to follow these instructions could result in serious injury or death.

## 2.1 - Serial Number

### Product Serial Number

Always give your dealer the serial number of your Pelsue confined space entry/retrieval product when ordering parts or requesting service or other information.

The serial number decal is permanently embossed with a serial number. The serial number decal will appear as shown in *Figure 2a* at the right and is located on the backside of the davit receiver tube on the center superstructure (see *Figure 2b*). A space has been provided below for the recording of the serial number for future reference.

MODEL: DBF-43A

Serial Number : \_\_\_\_\_

Date of Manufacture (DOM): \_\_\_\_\_

S/N#	_____
MODEL#	_____
DOM	_____

Figure 2a:  
Serial Number Decal

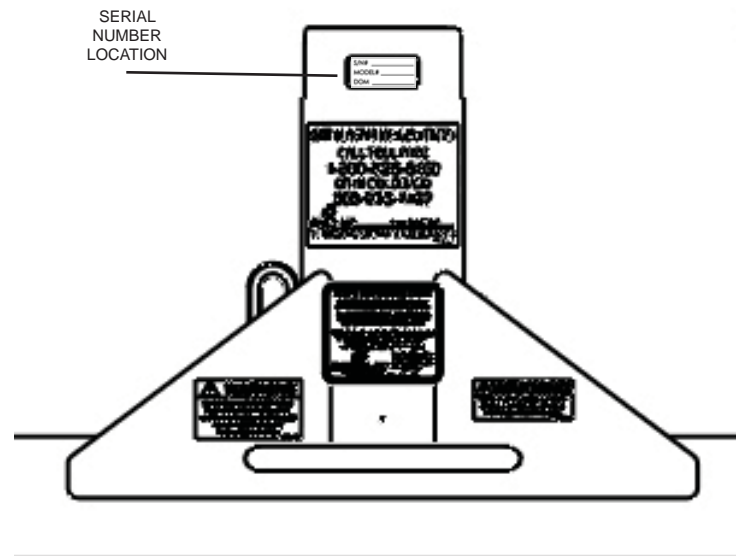

Figure 2b:  
Serial Number Decal Location

## 3.0 - Configuration & Assembly

Upon initial receipt of the DBF-43A system, inspect the packaging for any evidence that the product may have been damaged in shipment. While unpacking the product, inspect all of the components for damage. If damage to any of the components is discovered, DO NOT USE THE PRODUCT! Alert the shipping carrier immediately of the damage to the shipment.

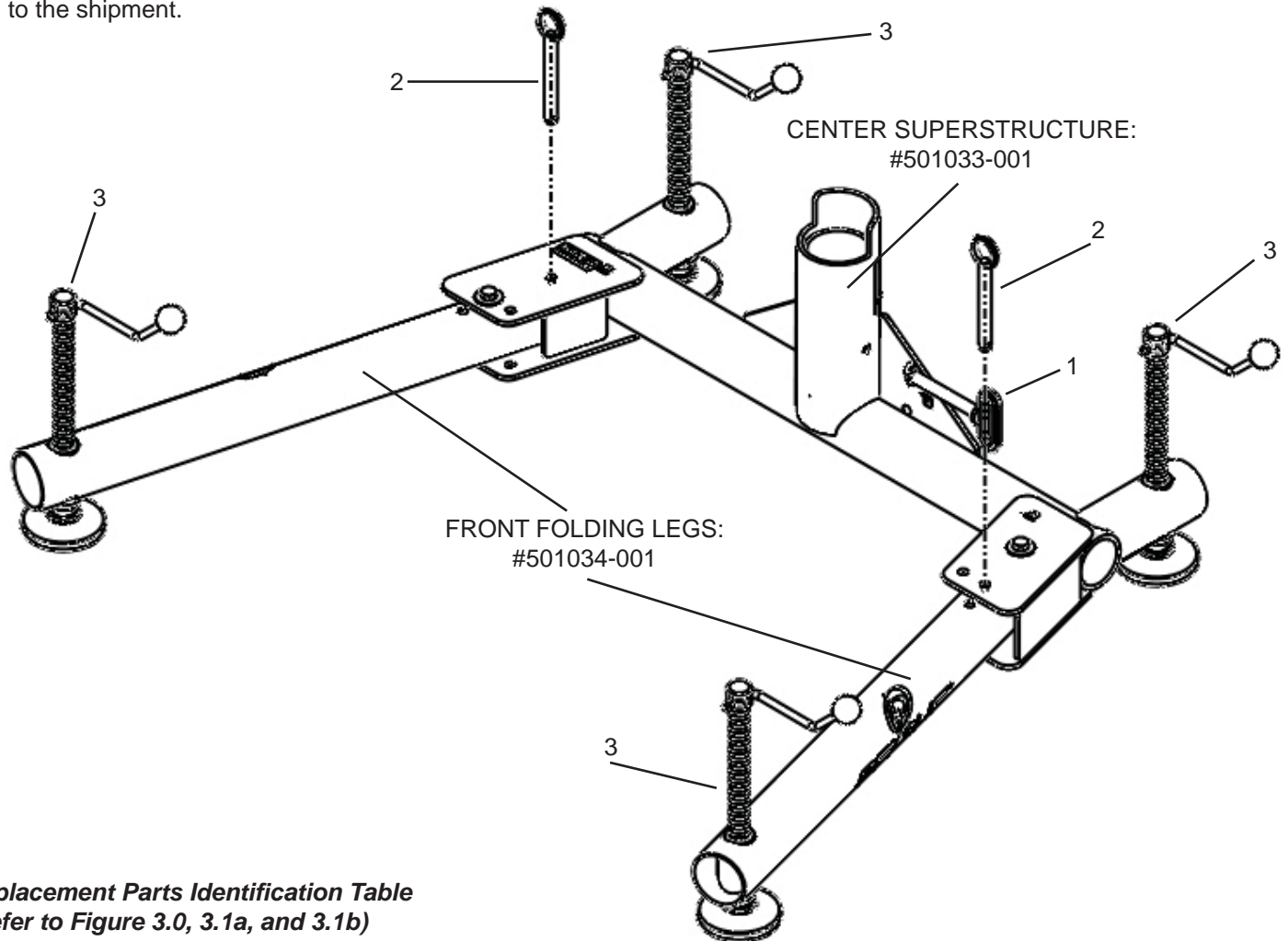

Figure 3.0: DBF-43A  
Parts Diagram

### Replacement Parts Identification Table (Refer to Figure 3.0, 3.1a, and 3.1b)

Item Number	Part Number	Description
1	120605-001	Pin - Hitch, 1/2" Dia. X 4-1/4" Long
2	500408-001	Pin & Lanyard (2X total per system)
3	500227-001	Leveling Jack Assembly (4X total per system)
4	500238-001	Decal - Attention
5	500234-001	Decal - MAF Warning
6	103299-001	Decal - Service & Parts Information
7	501046-001	Decal - Warning - Maximum 18" Offset

Verify that all parts are present before product use.  
The #DBF-43A is shipped fully assembled.

1. Ensure that the product has been shipped with all the necessary components and is in working order

\*\*Refer to parts list above for common replacement parts. If replacement parts are required, they can be ordered from the T.A. Pelsue Company at 800-525-8460.

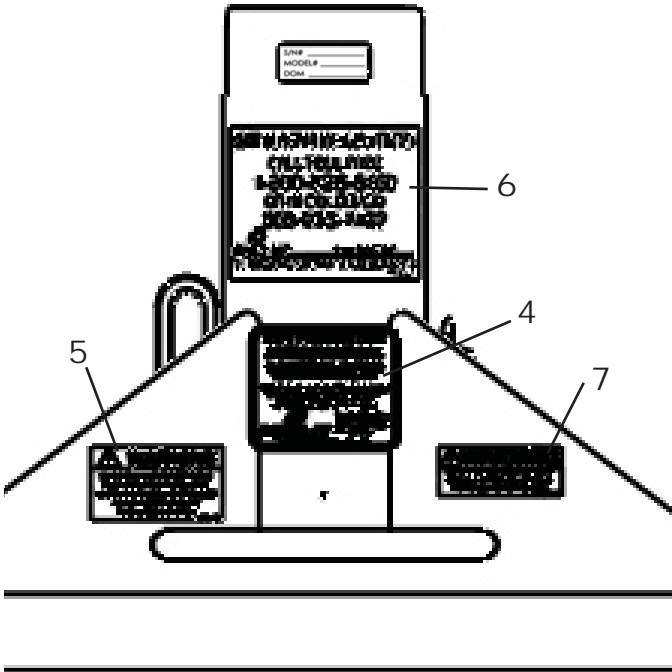

Figure 3.1a: DBF-43A  
Back Side Label Locations

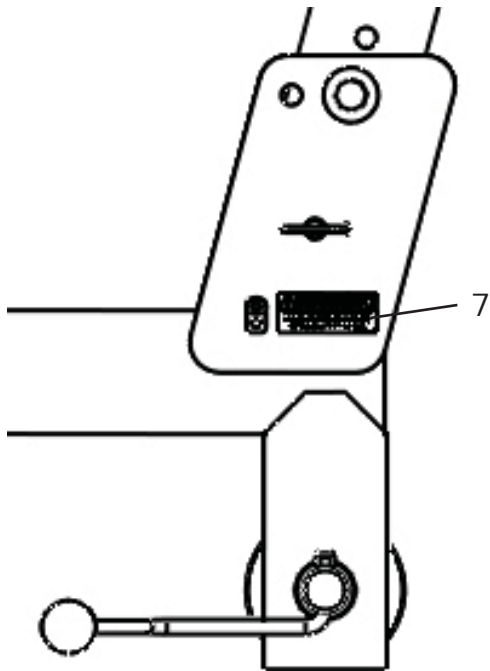

Figure 3.1b: DBF-43A  
Top Side Label Locations



4. 500238-001



5. 500234-001



6. 103299-001



7. 501046-001

## 4.0 - Safety

The following section will address the safety precautions which must be adhered to when working with Pelsue confined Space Safety equipment such as the DBF-43A Folding Davit Base. Any user must familiarize themselves with the information in this section before utilizing the equipment.

### SIGNAL WORDS:

Note the use of the signal words **DANGER**, **WARNING** and **CAUTION** with the safety messages. The appropriate signal word for each message has been selected using the following guidelines:

- DANGER-** Indicates an imminently hazardous situation that, if not avoided, will result in death or serious injury. This signal word is to be limited to the most extreme situations or for hidden or unseen hazards.
- WARNING-** Indicates a potentially hazardous situation that, if not avoided, could result in death or serious injury and includes obvious and hidden hazards. It may also be used to alert against unsafe practices.
- CAUTION-** Indicates a potentially hazardous situation that, if not avoided, may result in minor or moderate injury. It may also be used to alert against unsafe practices.

You are responsible for the safe operation, maintenance and inspection of your Pelsue DBF-43A Folding Davit Base. You must ensure that anyone who will operate, maintain, inspect or work around the equipment be familiar with the operating and maintenance procedures and related safety information contained in this manual. This manual will take you step-by-step through the workings and capabilities of the DBF-43A Folding Davit Base and alert you to all good safety and operating practices while using the system.

Remember, you are the key to safety. Good safety practices not only protect you but also the people around you. Make these practices a working part of your safety program. Be certain that everyone operating this equipment is familiar with the procedures recommended and follows safety precautions. Remember, most accidents can be prevented. Do not risk injury or death by ignoring good safety practices.

- System owners must give operating instructions to operators or employees before allowing them to use the equipment and at least annually thereafter.
- The most important safety device on this equipment is a safe operator. It is the operator's responsibility to read and understand all safety and operating instructions in the manual and to follow these. Most accidents can be avoided.
- A person must understand the operation of this equipment and be trained in its usage before operating the equipment. An untrained operator exposes himself and others to possible serious injury or death.
- Do not modify the equipment in any way. Unauthorized modification may impair the function and/or safety and could affect the life of the equipment.
- Think SAFETY! Work SAFELY!

### 4.1 - Warning Statement

#### WARNING!

Products manufactured or sold by the T.A. Pelsue Company are intended for use by professionals trained and experienced in the use, inspection and maintenance of these products.

Paraprofessional users such as volunteer rescue workers and sportsmen involved in risk sports such as climbing and caving will be held to the same standard of experience and training as professionals.

Technical rescue, repelling, climbing and the training involved are hazardous activities. Each situation has its own unique conditions and must be evaluated. Effective risk management comes from experience, proper training and good personal judgement.



### SAFETY ALERT SYMBOL

This Safety Alert symbol means **ATTENTION! BECOME ALERT! YOUR SAFETY IS INVOLVED!**

The Safety Alert symbol identifies important safety messages on your Pelsue Retrieval Product and in the manual. When you see this symbol, be alert to the possibility of personal injury or death. Follow the instruction in the safety message.



Why is this symbol important to you?

- 3 BIG Reasons:**
- Accidents Disable and Kill.**
  - Accidents Cost You Money.**
  - Accidents Can Be Avoided.**

## 4.3 - General Safety Information

1. Read, understand, and follow the Product Manual and all safety signs before using, maintaining or inspecting the equipment.
2. Refer to and follow applicable standards and regulations. Comply with requirements of local regulations for your applications.
3. Establish an equipment-use training program for inexperienced employees. Only trained, competent persons shall use the equipment. An untrained operator is not qualified to operate the system.
4. Have a first-aid kit available for use should the need arise and know how to use it.
5. Provide a fire extinguisher for use in case of an accident. Store in a highly visible place.
6. Install and properly secure all guards and shields before operating.
7. Wear appropriate protective gear. This list includes but is not limited to:
  - A hard hat
  - Protective shoes with slip resistant soles
  - Heavy gloves
  - Protective clothing
  - Face Protection
8. Review and follow the Pre-Operation Checklist before using a component in the system or system itself.
9. Establish a regular maintenance and inspection program with your equipment and maintain detailed records.
10. Review safety related items and operating instructions with all personnel on a regular basis.

## 4.4 - Operating Safety

1. Read, understand and follow the User Manual and signs on the product before using, maintaining or inspecting the equipment.
2. Train all operators before allowing them to use the product. An untrained operator exposes themselves, bystanders and workers to possible serious injury or death.
3. Visually inspect the product and all auxiliary components and equipment before using. Correct any problems before using the equipment.
4. Securely anchor the product before using.
5. Use only certified anchor and connector components in your system.
6. Use only an approved full body harness for the workers.

## 4.4 - Operating Safety (continued)

---

7. Always work in teams. One person is to work in the confined space (entrant) and the other is to attend to the entrant (attendant). Pelsue recommends an additional attendant/rescuer for stand-by in case of an emergency.
8. Do not exceed the capacity of the system at any time (see section 5.1).
9. Establish a regular training program for new and experienced workers.
10. Establish a detailed inspection program for your equipment and document the findings. Return the equipment to the manufacturer for repair if any problems are found.
11. Plan your work program before starting. Have the required people, equipment and procedures available to do the job.
12. Do not use the equipment around physical or environmental hazards. This list includes but is not limited to:
  - Corrosion that may affect the structural integrity of the lifeline or other components.
  - Chemicals which can degrade components in a manner which can not be visually identified.
  - Toxic gases: Rescuers or workers can be killed in toxic environments.
  - Heat or elevated temperatures.
  - Moving machinery: Workers or auxiliary equipment can be contacted by or pulled into moving components.
  - Sharp edges: Workers or the rescue equipment can be injured by or damaged by sharp edges or components.
  - Electrical hazards: Stay away from power lines or components carrying electrical power.
  - Overload: Do not overload the system at any time during operation (see section 5.1).
  - Follow confined space regulations and standards.

## 4.5 - Maintenance Safety

---

1. Read, understand and follow the User Manual and signs on the product before using, maintaining or inspecting the equipment.
2. ANSI and OSHA require a regular inspection program for all confined space entry/retrieval equipment and to maintain documented results of these inspections. Follow the inspection procedure contained in this manual and use the inspection form to document the results (see section 6.0).
3. Keep instructional and safety signs clean and legible at all times. Clean or replace as required.
4. Remove the equipment from service if a problem is found during the inspection. Return to an authorized repair depot or the factory for service.

## 4.6 - New Operator or Owner

---

The DBF-43A Folding Davit Base is designed to assist a person/entrant in entering a confined space and assist in exiting if required. Every new operator must read, understand and follow the instructions in the manual. No one should be allowed to use the equipment without training. The training should be reviewed with experienced operators on a regular basis. At regular intervals, perform a detailed inspection of the equipment and document the results. Remove from service if deficiencies are found. Alterations or misuse of this equipment or failure to follow instructions may result in serious injury or death.

It is the responsibility of the owner's organization or operator to read this manual and to train all other operators before they start working with the equipment. Follow all safety instructions exactly. Safety is everyone's business. By following recommended procedures, a safe working environment is provided for the operator, bystanders and the area around the work site. Untrained operators are not qualified to operate the equipment.

Many features incorporated into this equipment are the result of suggestions made by customers like you. Read this manual carefully to learn how to operate the equipment safely and how to set it to perform as intended. By following the operating instructions in conjunction with a good maintenance program, your product will provide many years of trouble free service.

# 5.0 - Product Operation

The following section will address the capabilities and the general operation of the DBF-43A Folding Davit Base. The instructions contained within this section should be adhered to each and every time the product is used. Any person tasked with installing or operating the piece of equipment should be familiar with these procedures.

## 5.1 - Product Description & Capabilities

The DBF-43A Folding Davit Base is built from structural aluminum, and has several steel and/or engineered plastic components. The DBF-43A Folding Davit Base is specifically designed to provide a lifting and lowering device and/or anchor point above a manway for a single person when used with a Pelsue DK Series Davit or a davit possessing a 3" outer diameter centerpost. The DBF-43A can be stowed and transported in its folded configuration, allowing for easy movement and placement. All specifications, instructions, and procedures provided within this manual or upon Pelsue Specification Documents are based upon and only valid for usage with a Davit having an offset of 18". The T.A. Pelsue Company can not verify equipment safety and/or compliance when utilized with anything other than Pelsue products.

### Folding Davit Base - DBF-43A

#### General Specifications

- Height - 15-1/2"
- Length - Deployed - 40"  
- Folded - 16-1/2"
- Width - Deployed - 50-1/2"  
- Folded - 42"
- System Weight - 35 lbs.
- Load Capacity (@ End of Davit Arm) - 350 LBS. (159 KG)

#### Load Capacity

- Single user with a maximum weight of 350 lb.
- Refer to loading diagrams for proof loads

#### Materials & Construction

- |                              |                                    |
|------------------------------|------------------------------------|
| <b>General Construction:</b> | <b>Structural Aluminum</b>         |
| • Anti-Friction              | - ABS and/or PVC                   |
| • Hardware                   | - Plated Steel                     |
| • Leveling Jacks             | - Alloy Steel Threaded Rod, Plated |

#### Features:

- Easily assembles over most manholes for safe and secure lifting and/or placement of personnel
- Provides a anti-friction-lined receiver compatible with any Pelsue Davit System
- Independently adjustable leveling jacks provide any inconsistencies in surface level

! CAUTION ! - The user must ensure that the ground area or base structure utilized for operation is capable of withstanding the weight of the system combined with the system proof loads in order to retain the stated compliance of the entire system.



! CAUTION ! - The DBF-43A davit base is only approved for usage with davit systems having a maximum offset of 18".

! CAUTION ! - The user must ensure that the ground area utilized for operation is relatively level and debris-free in order to retain the stated compliance and stability of the entire system.

! CAUTION ! - The user must ensure that the bolt and pins are locked in place when the two front legs are deployed in order to retain the stated compliance of the entire system.

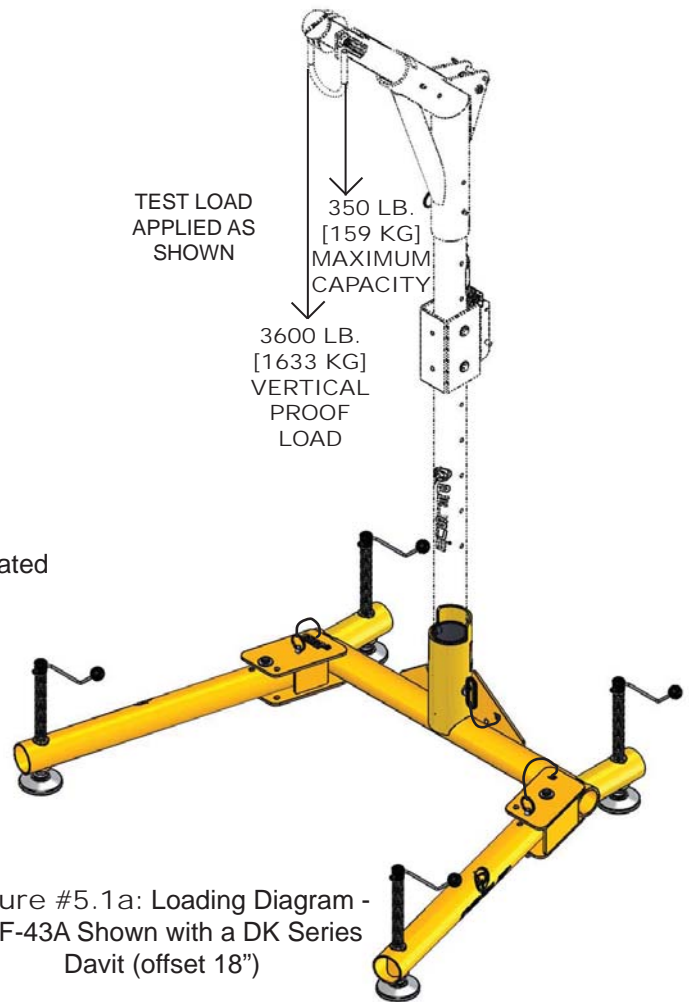
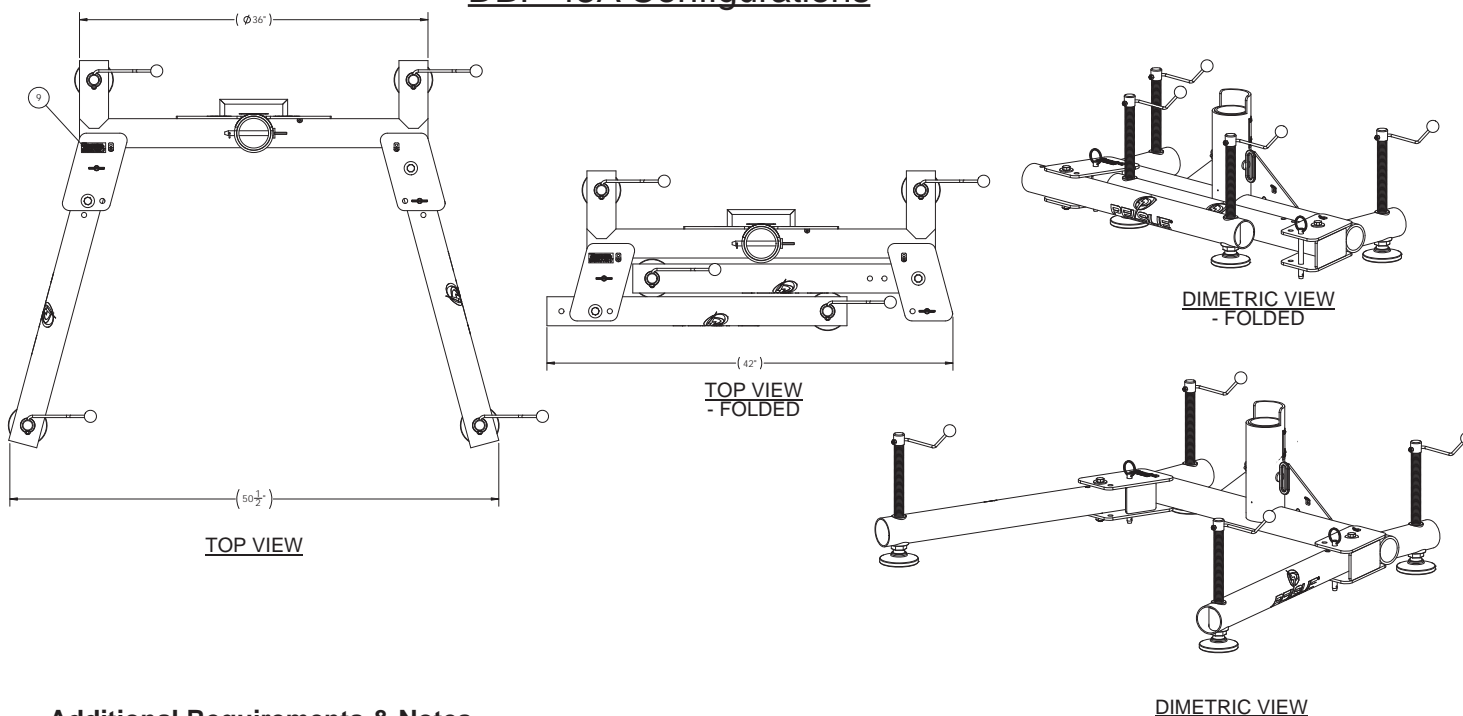

Figure #5.1a: Loading Diagram - DBF-43A Shown with a DK Series Davit (offset 18")

## 5.1 - Product Description & Capabilities (continued)

### DBF-43A Configurations



#### Additional Requirements & Notes

- The DBF-43A is only to be utilized within the guidelines and ratings presented in this manual and only by personnel who are trained in the operation of this equipment as well as the practices of general confined space safety.

## 5.2 - Product Installation & Set-up

Prior to Operation, the DBF-43A Davit Base should be configured and prepared according to the following guidelines.

#### 1. Pre-Operation Inspection:

It is necessary to perform a visual inspection prior to each time using the product. If deficiencies are found, remove the product from service and contact the T.A. Pelsue Co. regarding repair. The following checklist coupled with *Figure #5.2a* should be used as a guide to determine whether the equipment is in good operating condition prior to usage. Equipment that is not in good condition can endanger the safety of the entrant and attendant during use.

The Pre-Operation Visual Inspection is not limited to, but must include the following items;

- Check that the product has no structural defects, such as dents, bends, cracks, or fractures.
- Ensure that all product rating & warning labels are clear and legible.
- Check that front legs fold smoothly in and out between the mounting plates.
- Check that the leveling jacks turn freely and that the threads are in good condition.
- Check that all hardware (Pins, Leveling Screws, Bolts) have not been damaged and is in working condition.

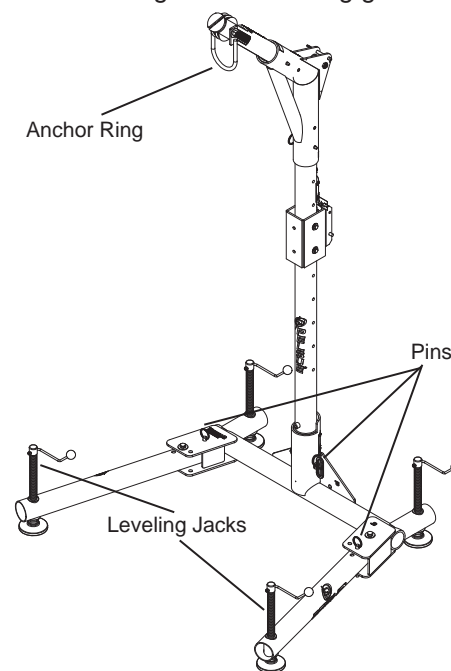

Figure #5.2a: DBF-43A  
Pre-Operation Inspection Points

## 5.2 - Product Installation & Set-up (continued)

### 2. Setup of DBF-43A Folding Davit Base:

Choose a location where installation will provide suitable proximity to the work area yet minimize obstructions during use and in the event a rescue is necessary. Once a location is chosen;

- The two front legs of the base must first be deployed prior to installing the Davit. Unfold the front legs ensuring that the bolts holding the legs to the base are securely fastened. Then pin the legs in the provided holes to lock the legs in place. The pins must be fully inserted and protruding out the underside of the base. (Refer to Fig. #5.2b)
- Insert a davit (**With a Maximum Offset of 18"**) into the superstructure. (Refer to Fig. #5.2c)
- Align the holes in the davit and the holes in the superstructure and pin the two in place if desired, or the davit can be allowed to rotate. (Refer to Fig. #5.2c).
- After the Folding Base and Davit are pinned in place, the system can be moved over to the manway. (Refer to Fig. #5.2d)
- Next the leveling jacks must be adjusted in order to properly level the system. (Refer to Fig. #5.2d).
- Operate the assembled system taking into account the operating requirements of the davit and any added mechanical device secured to the davit.
- For disassembly, remove davit and replace hitch pin into base. Then remove pins that lock the two front legs and fold the legs inward. Re-insert pins in base to lock the legs in the folded position.

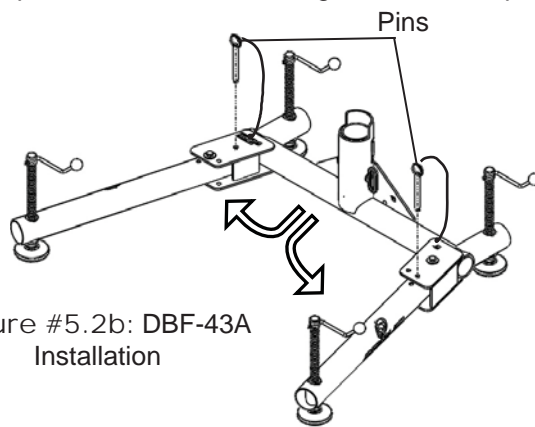

Figure #5.2b: DBF-43A Installation

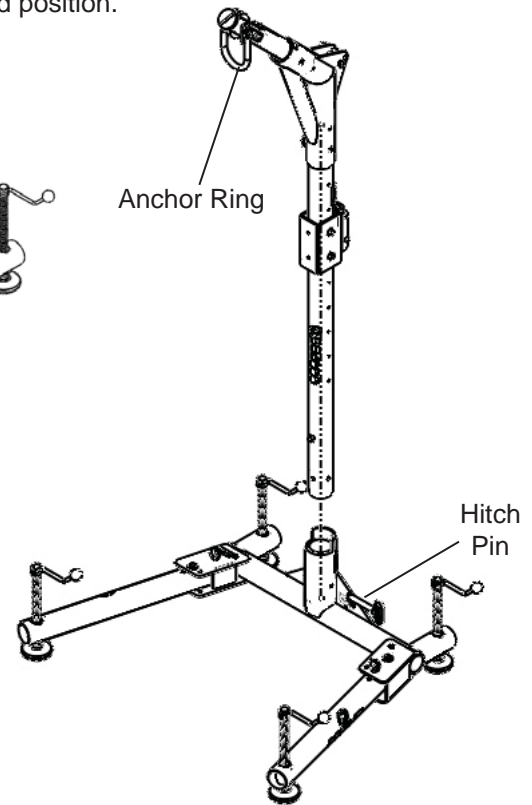

Figure #5.2c: Davit Installation

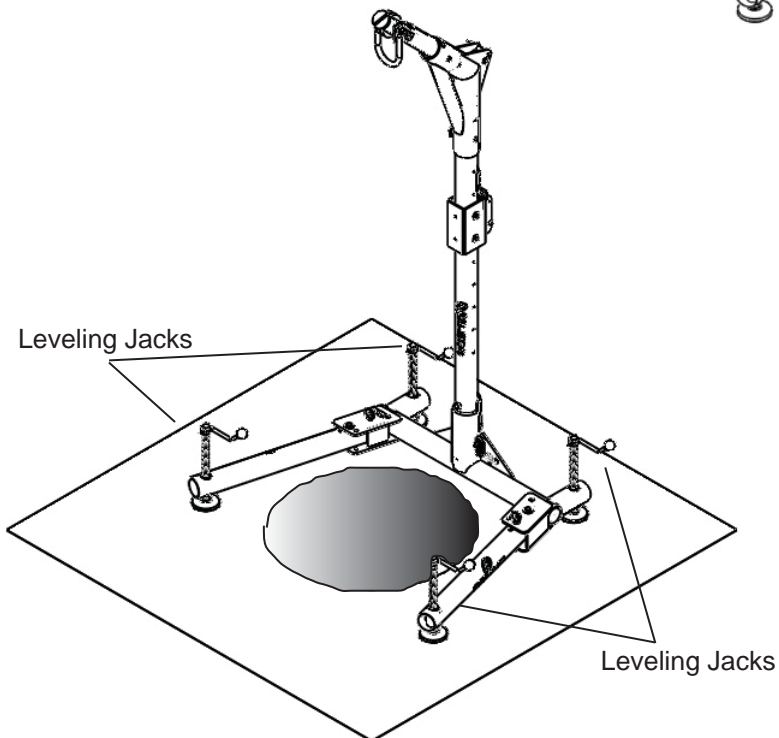

Figure #5.2d: DBF-43A & Davit Completely Installed

**!WARNING!** - The user must ensure that the leveling jacks are secure and pins are correctly installed in order to prevent damage to the product and injury to the operator.

**!WARNING!** - When using the DBF-43A folding base as part of a complete fall arrest system, all lifeline connections to any davit installed within the DBF-43A folding base must be made via a 900 LB. MAF Device.

## 6.0 - Maintenance & Inspection

---



### **MAINTENANCE & INSPECTION**

1. Read, understand and follow the Product Manual and signs on the product before using, maintaining or inspecting the equipment.
2. ANSI and OSHA require a regular inspection program for all confined space entry/retrieval equipment and to maintain documented results of these inspections. Follow the inspection procedure contained in this manual and use the inspection form to document the results.
3. Keep instructional and safety signs clean and legible at all times. Clean or replace as required.
4. Remove the equipment from service if a problem is found during the inspection. Return to an authorized repair depot or the factory for service.

### 6.1 - Maintenance

---

For the most part, the DBF-43A is intended to be a maintenance-free piece of equipment, however several steps can be taken to keep the system in top-notch working order and also extend the working life of the product.

Before Each Use:

1. Visual Inspection: Perform a complete visual inspection. Refer to section 6.2 for guidelines and take any maintenance steps that are necessary.

Annually:

1. Clean Product: Use a damp cloth and mild soap to clean the structure and labels of dirt and residue. Be sure the labels are legible (replacements are available from Pelsue)
2. Complete Inspection: Perform a thorough inspection, paying attention to the bullet points provided within section 6.2. Record results and keep documentation. A log has been provided in section 6.3 specifically for the recording of the dates & results of annual system inspections.

Periodic Factory Service Inspection: It is recommended that the product be serviced by a factory authorized service center or the manufacturer after a period of three years. Extreme working conditions may indicate the necessity to increase the frequency. Factory servicing shall include but not be limited to an intensive inspection and cleaning of all internal and external components. Failure to provide proper service may shorten product life and could endanger performance or function.

### 6.2 - Inspection

---

When completing an inspection of the DBF-43A Folding Base, the following specific items should be checked;

1. Labels:

Check that all the labels are clean and legible. Clean the labels if any are dirty using mild soap and a damp cloth. Replace if any are illegible. Decals & labels provide valuable warning and caution information applicable to product usage and limitations, and should be visible and present at all times.

2. Pins & Fasteners:

Check that all screws and other fasteners are present and secure. Note that not all fasteners are tightened to their maximum allowable torque. This is done in order to allow for pivoting and folding motions in certain components. Over-tightening of fasteners can interfere with the operation of the device and can damage the structure.

All fasteners on the DBF-43A system are of a self-locking design. Bolt threads should extend all the way through their locking nuts. If any fasteners have appeared to "back-out" or loosen the product should be removed from service until the problem can be identified and corrected.

### 3. Leveling Jacks:

Ensure that the leveling jacks are securely fastened and that they are not bent and there are no loose parts. Also, visually inspect the leveling jacks for any sign of deformation. The leveling jacks should operate smoothly, lubricate the threads if necessary

### 4. Structure:

The entire product structure should be checked for cracks, gouges, dents, bends or breaks. If there are major dents or any other structural damage, the unit should be removed from service and returned to the factory for repair.

- Pay special attention to weld locations: look for cracks or separation at the welds. Keep in mind the powder coating can age and crack, this normal paint cracking can be confused with structural cracking. If there is any uncertainty with regards to cracks, contact the Pelsue service department for assistance and/or recommendations
- Ensure that the two outriggers can move easily within the superstructure without obstructions. Binding of the outriggers may be indicative of further structural deformation.

# 6.3 - Inspection Log

**Model Number :** DBF-43A

**Serial Number :**

**Date Purchased :**

*Place a check (✓) in the box if item is acceptable, place an x (X) in the box if item requires maintenance or repair*

Date	Labels	Pins & Fasteners	Leveling Jacks	Overall Structure	Notes
Inspector (print & sign) :					
Inspector (print & sign) :					
Inspector (print & sign) :					
Inspector (print & sign) :					
Inspector (print & sign) :					
Inspector (print & sign) :					
Inspector (print & sign) :					
Inspector (print & sign) :					
Inspector (print & sign) :					

Date	Labels	Pins & Fasteners	Leveling Jacks	Overall Structure	Notes
Inspector (print & sign) :					
Inspector (print & sign) :					
Inspector (print & sign) :					
Inspector (print & sign) :					
Inspector (print & sign) :					
Inspector (print & sign) :					
Inspector (print & sign) :					
Inspector (print & sign) :					
Inspector (print & sign) :					

### 6.3 - Inspection Log (continued)

---

## 7.0 - Storage

---

Prior to storage, the product should be thoroughly inspected and maintained. Repair or replace any worn or damaged components to prevent any unnecessary down time at the next use.

Follow this procedure:

1. Thoroughly clean the entire unit using a mild soap on the frame and labels.
2. Perform a complete inspection of the unit and document the results prior to storage.
3. Oil or grease hinges and moving components in order to prevent corrosion.
4. The DBF-43A system can be folded for storage and transport if desired, instructions given for assembly in section 3.0 of this manual.

## 8.0 - Contact Information

---

For More Information...



**T.A. Pelsue Company**  
**2500 S. Tejon St.**  
**Englewood, CO 80110**

**Toll Free:** 1-800-525-8460  
**Telephone:** 1-303-936-7432  
**Fax:** 1-303-934-5581

**Website:** [www.pelsue.com](http://www.pelsue.com)

**Email:** [sales@pelsue.com](mailto:sales@pelsue.com)

# Notes

---





T.A. Pelsue Company  
2500 South Tejon Street, Englewood, Colorado, USA 80110  
Toll free 800-525-8460 or 303-936-7432 Fax. 303-934-5581  
Internet: [www.pelsue.com](http://www.pelsue.com) Email: [sales@pelsue.com](mailto:sales@pelsue.com)