



# Installation, care and maintenance

---

Drainage pump, Ready 4, Ready 8, Ready 16, Ready 24



# CONTENTS

<b>Product description</b> _____	3	<b>Electrical connections</b>	
Applications _____	3	Level Regulators _____	5
Technical data _____	3	Ready 4 & 8 _____	6
Motor data _____	3	Ready 16 & 24 _____	7
Dimensions _____	3		
		<b>Operation</b> _____	8
<b>Performance curves</b> _____	4	<b>Care and maintenance</b> _____	9
		Inspection _____	9
<b>Installation</b> _____	5	Tightening & Lubricating screws _____	9
		<b>Spare parts</b> _____	10

## DATA PLATE INTERPRETATION

### Ready 4 & 8

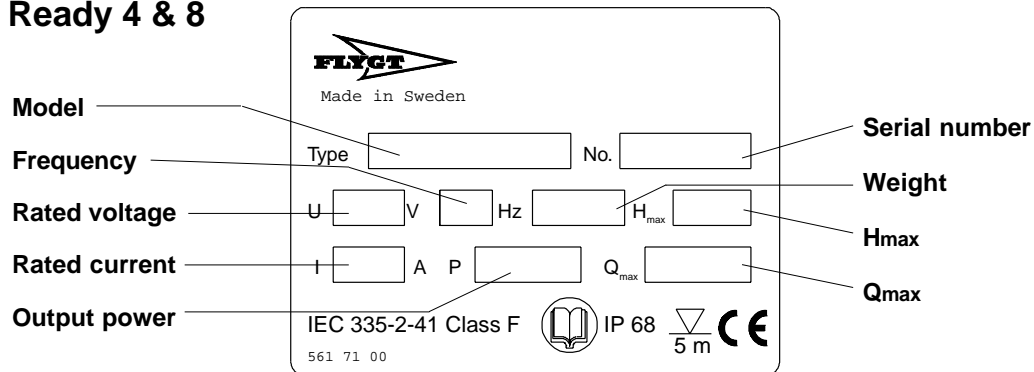

### Ready 16 & 24

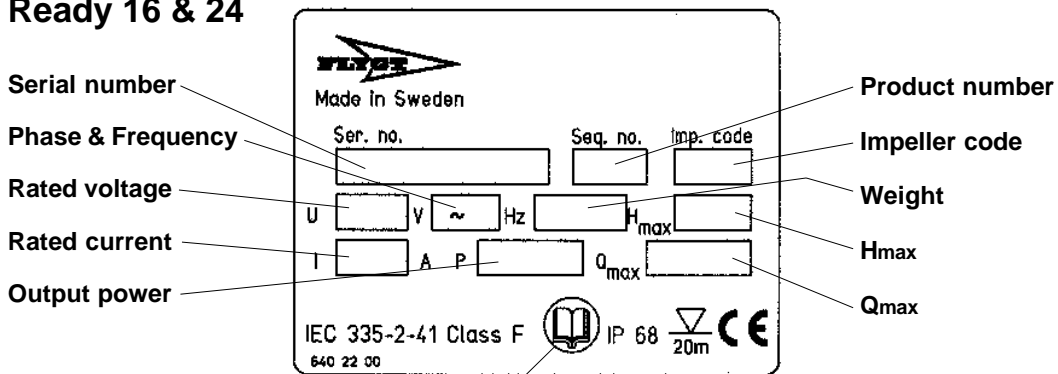

**Note!**

The manual is to be read before installing or operating the pump.

### Warranty claim

Flygt pumps are high quality products with expected reliable operation and long life. However, should the need arise for a warranty claim, please contact Your Flygt representative.

# PRODUCT DESCRIPTION

## Applications

READY 4, 8, 16 and 24 pumps are intended to be used for pumping water which may contain abrasive particles. The pumped liquid may contain particles up to a size which corresponds to the openings in the strainer.

## Technical data

**Liquid temperature:** 5–35°C (41–95°F).

**The pH of the pumped liquid:** 3–9.

**Depth of immersion:** Ready 4 & 8, max 5 m (16.5 ft)  
Ready 16 & 24, max 20 m (65 ft)

### Weight without motor cable:

READY 4	9 kg	(20 lb)
READY 8	11.5 kg	(25 lb)
READY 16, 3~	17,7 kg	(36 lb)
READY 16, 1~	19 kg	(42 lb)
READY 24, 3~ & 1~	19 kg	(42 lb)

### Discharge connection:

50 mm (2") hose, 2"–11.5 NPSM or ISO G2.  
75 mm (3"), hose, 3"–8 NPSM or ISO G3 (R16 & R24)

### Oil type:

Mobil Whiterex or Shell Ondina etc. with viscosity class ISO VG 15 to 32.

### Oil volume:

Ready 4 & 8 = 0.17 litre  
Ready 16 & 24 = 0.19 litre

## Motor data READY 4

50 Hz, 1~, 400 W, 2700 r/min      60Hz 1~, 0.6 hp (440 W)  
3200 r/min

Voltage V	Rated Current A	Starting Current A	Voltage V	Rated Current A	Starting Current A
115	5.1	17	115	5.5	16
230	2.5	6.5	230	2.9	6

## Motor data READY 24

50Hz 3~, 2.4 kW, 2700 r/min      60Hz 3~, 3.8 hp (2.8 kW),  
3300 r/min

Voltage V	Rated Current A	Starting Current A	Voltage V	Rated Current A	Starting Current A
220	9.4	42	460	5.1	26
230	9.3	44	480	5.0	28
380	5.5	23	600	3.9	22
400	5.3	24			
415	5.3	25			
440	4.8	22			

60Hz 1~, 3.0 hp (2.2 kW),  
3360 r/min

Voltage V	Rated Current A	Starting Current A
230	13	39
240	13	41

## Motor data READY 8

50 Hz, 1~, 750 W, 2800 r/min      60Hz 1~, 1.1 hp (850 W) 3200 r/min

Voltage V	Rated Current A	Starting Current A	Voltage V	Rated Current A	Starting Current A
115	10.8	40	115	9.8	36
230	4.3	15	230	4.9	14

## Motor data READY 16

50Hz 3~, 1.7 kW, 2800 r/min      50Hz 1~, 1.5 kW, 2750 r/min

Voltage V	Rated Current A	Starting Current A	Voltage V	Rated Current A	Starting Current A
220	6.8	28	220	9.4	27
230	6.6	29	230	8.9	28
380	3.9	16	240	8.7	30
400	3.8	17			
415	3.9	18			
440	3.4	15			
500	3.0	13			

60Hz 1~, 2.3 hp (1.7 kW),  
3400 r/min

Voltage V	Rated Current A	Starting Current A
230	10.2	38
240	10	40

60Hz 3~, 2.7 hp (2 kW),  
3300 r/min

Voltage V	Rated Current A	Starting Current A
230	7.3	37
460	3.6	19
480	3.6	20
600	2.8	15



**WARNING!**  
The pump may not be used in an explosive or flammable environment or for pumping flammable liquids.

## Dimensions:

### Ready 4 & 8

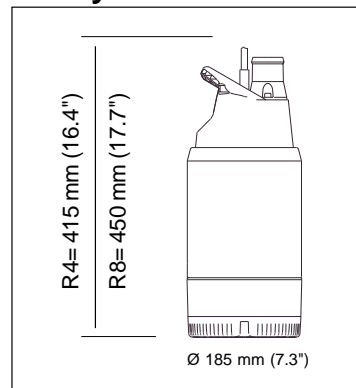

### Ready 16 & 24

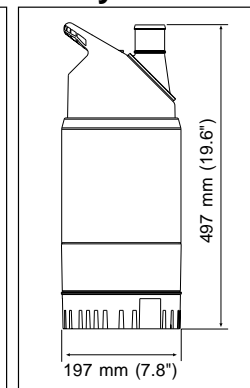

# PERFORMANCE CURVES

Each pump is tested in accordance with ISO 2548.

**READY 4, 50 Hz**

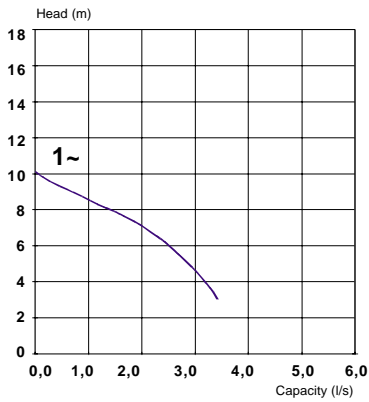

**READY 4, 60 Hz**

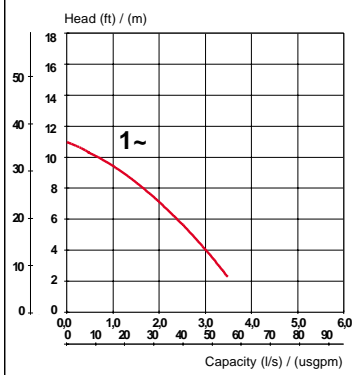

**READY 8, 50 Hz**

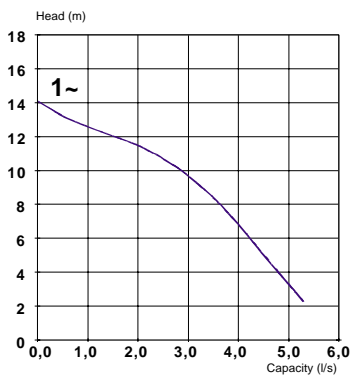

**READY 8, 60 Hz**

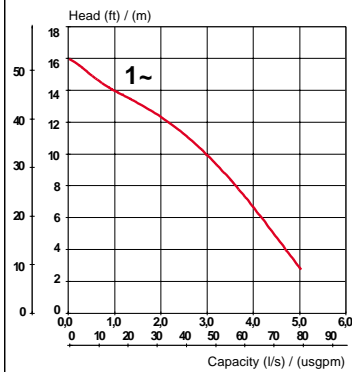

**READY 16, 50 Hz**

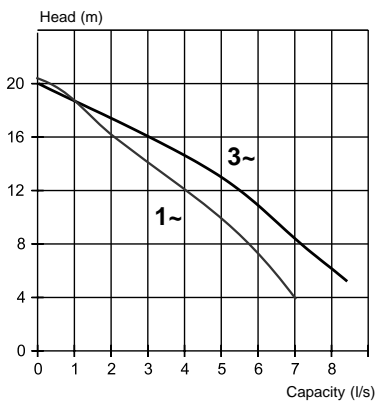

**READY 16, 60 Hz**

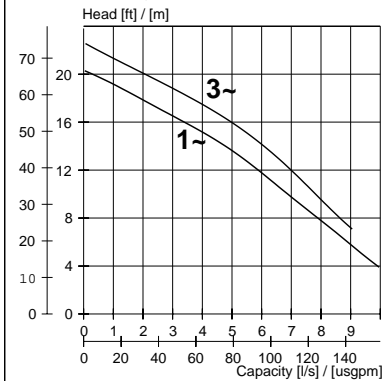

**READY 24, 50 Hz**

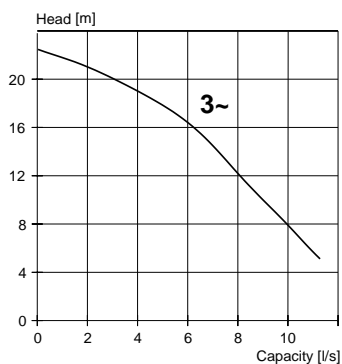

**READY 24, 60 Hz**

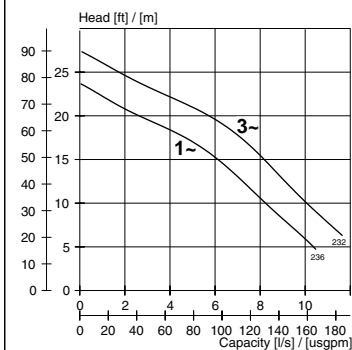

# INSTALLATION

## Pump installation

Run the cables so that they do not have any sharp bends and are not pinched.

Connect the discharge connection and motor cable. See "Electrical connections".

Lower the pump into the sump.

Place the pump on a base which will prevent it from sinking into a soft sump bottom. Alternatively, the pump can be suspended by its handle just above the sump bottom.



### NOTE!

Where required by local authorities an acceptable motor-circuit switch or other disconnecting device shall be provided at the time of installation.



### NOTE!

At certain installations and operation points on the pump curve the noise level 70 dB, or for the actual pump specified noise level, can be exceeded.

# ELECTRICAL CONNECTIONS



### WARNING!

All electrical equipment must be earthed (grounded). This applies to both pump equipment and any monitoring equipment. Failure to heed this warning may cause a lethal accident. Make sure that the earth (ground) lead is correctly connected by testing it.

All electrical work shall be carried out under the supervision of an authorized electrician.

Local codes and regulations shall be complied with.

Check that the mains voltage and frequency agree with the specifications on the pump data plate.

**NOTE!** For safety reasons, the earth (ground) lead should be approx. 50 mm (2") longer than the phase leads. If the motor cable is jerked loose by mistake, the earth (ground) lead should be the last lead to come loose from its terminal. This applies to both ends of the cable.

Make sure that the pump is correctly earthed (grounded).

## Level Regulators, Ready 4 & 8 only

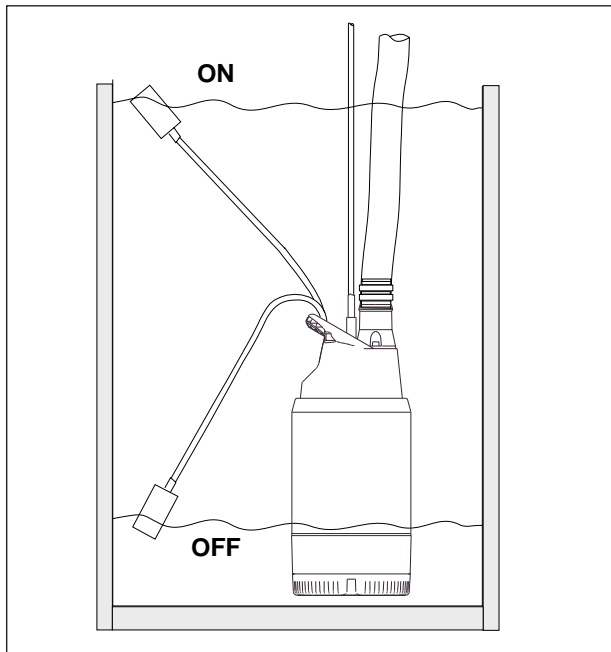

Ready 4 and 8 are available in two versions: with or without level regulator.

# ELECTRICAL CONNECTIONS

Ready 4 & 8

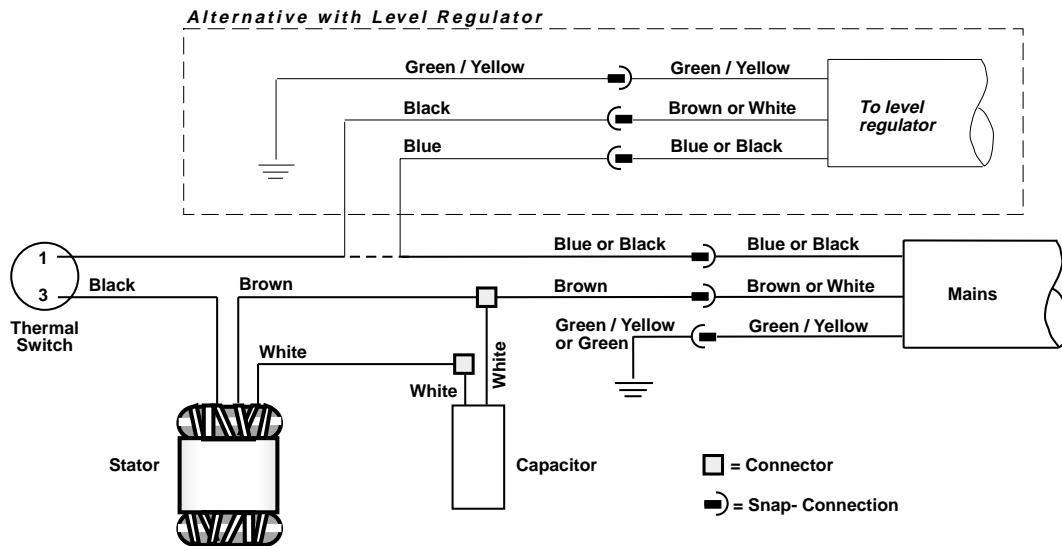

## WARNING !

If persons are likely to come into physical contact with the pump or pumped media (liquid), e.g on construction sites or farms etc, the earthed (grounded) socket must have an additional earth-(ground)-fault protection device (GFI) connected. When pumping near a lake (Jetties, beaches, ponds and fountains etc) a safety-distance of at least 20 meters (65 ft) between the person and the pump is applicable. The pump must never be placed directly into a swimming pool. If used in connection with swimming pools, special safety regulations apply.

Ready 16, 1~, 50Hz

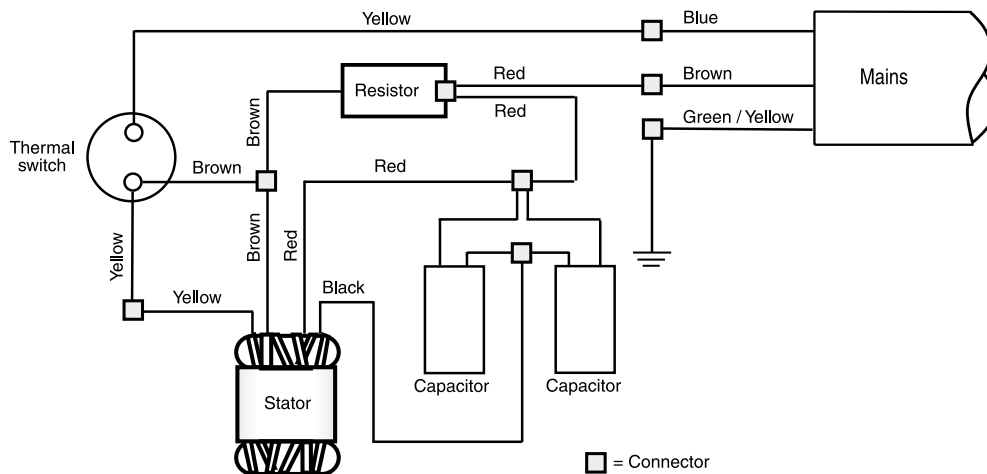

# ELECTRICAL CONNECTIONS

Ready 16 & 24, 3~, 50Hz & 60 Hz

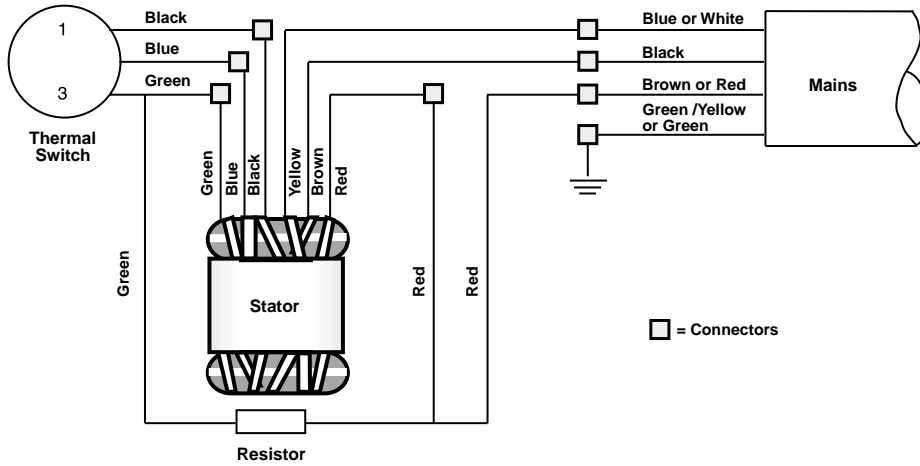

## WARNING !

If persons are likely to come into physical contact with the pump or pumped media (liquid), e.g on construction sites or farms etc, the earthed (grounded) socket must have an additional earth-(ground)-fault protection device (GFI) connected. When pumping near a lake (Jetties, beaches, ponds and fountains etc) a safety-distance of at least 20 meters (65 ft) between the person and the pump is applicable. The pump must never be placed directly into a swimming pool. If used in connection with swimming pools, special safety regulations apply.

Ready 16 & 24, 1~, 60 Hz

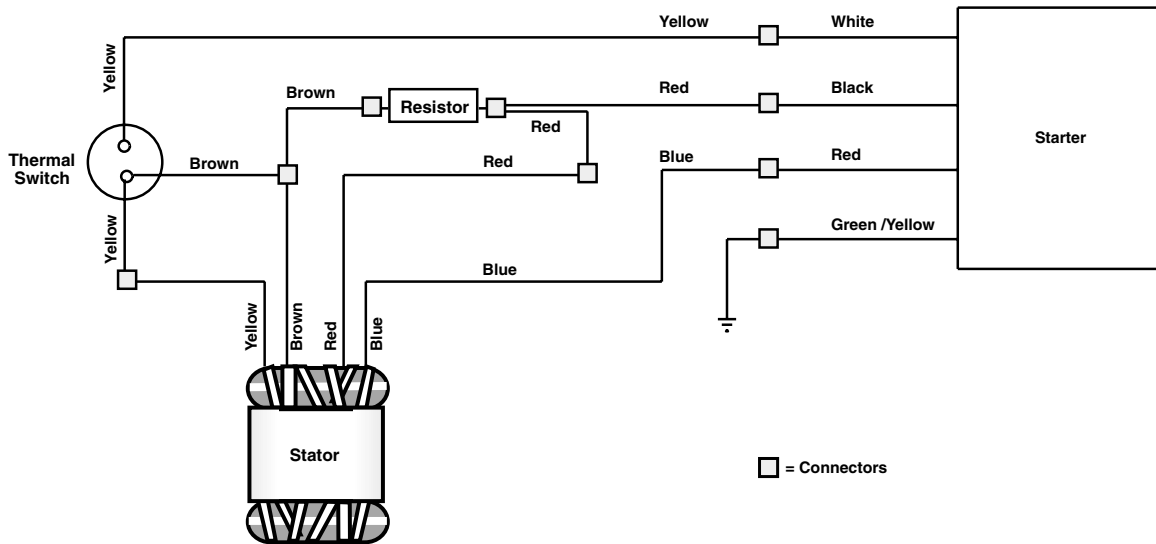

# OPERATION

## Before starting

Check the oil level in the oil casing.

Remove the fuses or open the circuit breaker and check that the impeller can be rotated by hand.

Check that the monitoring equipment (if any) works.

Check the direction of rotation. The impeller shall rotate clockwise, as viewed from above. When started, the pump will jerk in the opposite direction to the direction in which the impeller rotates. See the figure.

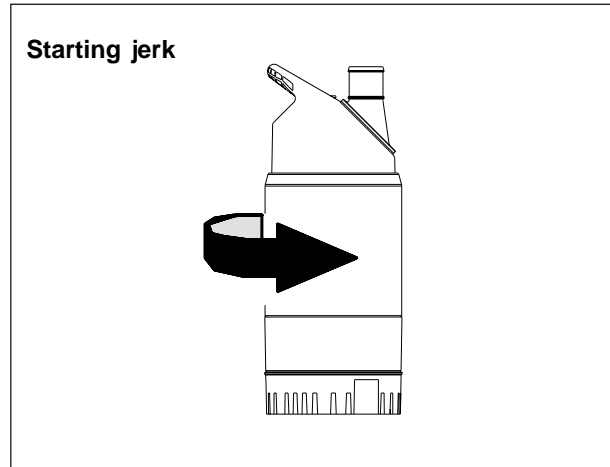

## Cleaning

If the pump has been running in very dirty water, let it run for a while in clean water, or flush it through the discharge connection. If clay, cement or other similar dirt is left in the pump it may clog the impeller and seal, preventing the pump from working.

During a longer period out of operation, the pump must be test run every other month to prevent the mechanical seals from sticking together.



### WARNING!

Watch out for the starting jerk, which can be powerful.



### WARNING!

Always lift the pump by its carrying handle or lifting eyes, never by the motor cable or the hose.

# CARE AND MAINTENANCE

## Inspection

Regular inspection and preventive maintenance ensure more reliable operation.

The pump should be inspected at least twice a year, more frequently under severe operating conditions.

## Tightening screws on Ready 4 & 8

During assembly or service of the Ready 4 & 8 pumps we recommend that the screws be tightened to approximately 6–8 Nm (4.5–6 ft lbs).

## Tightening screws on Ready 16 & 24

During assembly or service on the Ready 16 & 24 pump we recommend that the screws be tightened to the following torque values:

Screws with M6 thread = 7 Nm (5 ft lbs)

Screws with M6 thread = 12 Nm (9 ft lbs)  
on bearing cover.

Screws with M8 thread = 17 Nm (12.5 ft lbs)

M8 Centre-screw (3a) = 7 Nm (5 ft lbs)  
inside junction box.



### WARNING!

Be sure to disconnect the power supply before attempting inspection, as the pump may start automatically.

### NOTE!

Make sure that the cable gland-nut (2a), strainer securing screws and oil-plug screw (12) are not tightened too hard.

The tightening torque listed above ensures that the parts are correctly fastened and that the pumps will operate as intended.

## Lubricating screws

To maintain screw tightness use a little mineral oil on all non-stainless screws (not synthetic lubricants!).

### NOTE!

When using stainless steel screws on stainless steel parts we recommend that ARAL DEGOL GS 460 or National Chemseal THREAD-EZE lubricants be used to prevent screws from seizing or getting stuck.

## Thermal compound paste

The thermal compound paste under the thermal sensor is part of the motor protection system and should not be removed.

# SPARE PARTS

## Spare Part kits

Spare parts for the READY 4, 8, 16 & 24 pumps are available in handy kits to make service and repair work easier. Each kit contains an instruction sheet together with the replacement parts.

When ordering please refer to the Kit part numbers listed below:

Kit type	R4 400W 50Hz, Kit No.	R4 440W 60Hz, Kit No.	R8 750W 50Hz, Kit No.	R8 850W 60Hz, Kit No.	R16 & 24 3~ & 1~ 50Hz & 60Hz
Impeller Kit	618 12 00	618 12 01	618 13 00	618 13 01	ONREQUEST
Diffuser Kit	618 14 00	618 14 00	618 14 00	618 14 00	ONREQUEST
Outer seal Kit	621 02 00	621 02 00	621 02 00	621 02 00	ONREQUEST
Complete seal Kit	618 16 00	618 16 00	618 16 00	618 16 00	ON REQUEST

### Each Kit contains the following parts:

Impeller Kit	Impeller, Impeller screw, Protective plug, Washer, Assembly instruction
Diffuser Kit	Diffuser, Barrel nuts, Screws, Washers, Assembly instruction
Outer seal Kit	Mechanical face-seal unit, Assembly instruction
Complete seal Kit	Inner and outer mechanical seals, circlip, assembly instruction.

Please contact your local READY dealer for further details regarding spare parts etc.

## Main parts

### Item Denomination

1. Discharge connection
2. Cable entry
- 2a. Cable gland-nut
3. Handle/cover
- 3a. M8 Centre-screw
4. Support bearing
5. Pump casing
6. Main bearing
7. Inner mechanical seal
8. Outer mechanical seal
9. Impeller
10. Diffuser
11. Strainer
12. Oil plug
13. Motor

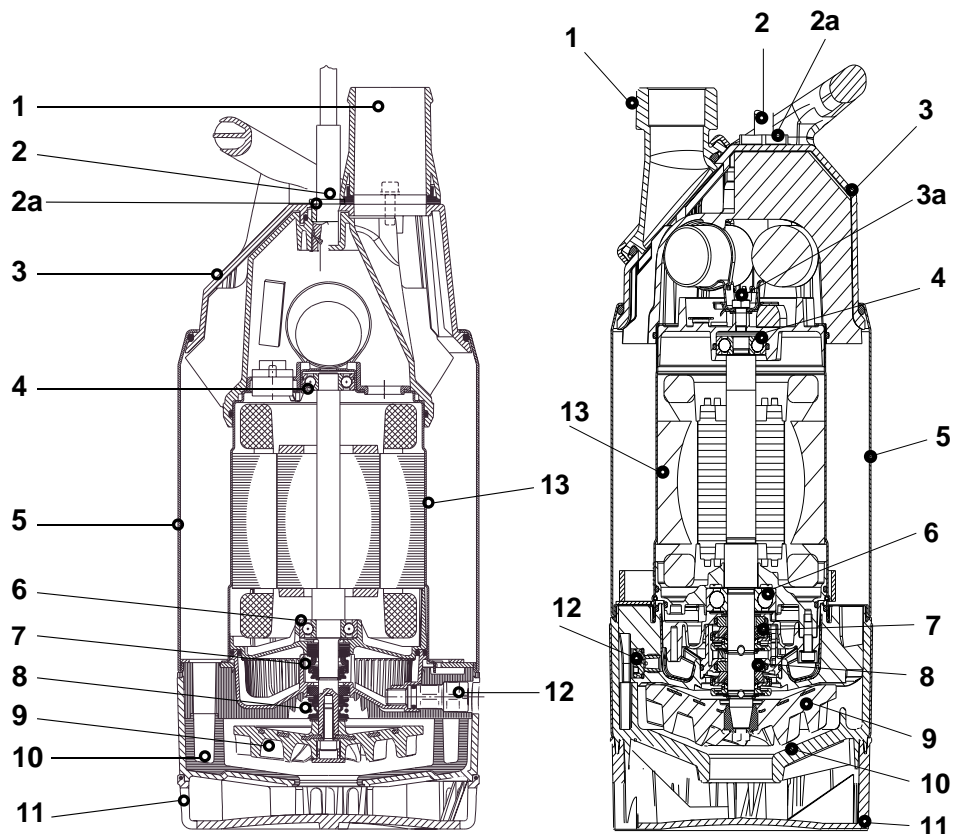

Ready 4 & Ready 8

Ready 16 & Ready 24

# NOTES

A series of horizontal dotted lines for writing notes.

