



Product Specifications

Model: FLO-CHEK Audible & Visual Air Flow Alarm

The Pelsue Model "FLO-CHEK" is a completely portable and cordless air flow monitoring and alarm system. Such a system is invaluable in the safe entry of a properly-ventilated confined space. The unit is battery powered via internal, rechargeable batteries and its sensor probe can be secured to any variety of ventilation duct or hose. When "powered on" the internal circuitry of the device will sense a drop in air flow and will respond by emitting an audible and visual warning alarm. On-board LED lighting and a compact speaker unit provide the warnings. A charging jack is built-into the FLO-CHEK's enclosure, and a charging unit is included which will charge the batteries from any standard 120VAC wall receptacle in under 8 hours. A fully-charged unit will operate in "alarm-mode" for over 5 days continuously. A 15' long sensor hose is included, enabling the placement of the enclosure and alarm up to 15' away from the location of the probe. The enclosure is equipped with a hook & loop strap allowing it to be secured in a suitable location.

General Specifications:

- Audible & Visual Air Flow Alarm
- Power Supply: 3X on-board AAA size rechargeable Nickle Cadmium Batteries
- Water & Impact Resistant
- Charge Time: Under 8 Hours
- Operation on Full Charge: Over 120 Hours

Materials & Construction:

- Enclosure.....ABS Plastic
- Boot.....Silicone Rubber
- Sensor
Hose.....PVC
- Hose Securing
Clamp.....Plastic & Rubber
- Hardware.....Stainless Steel

Dimensions:

Enclosure.....6.5" x 3.5" x 1.5"
Clamp.....9.0" x 4.0" x 1.3"
Weight.....1 LB. (0.45 kg.)



FLO-CHEK ASSEMBLY



2500 S. Tejon St.
Englewood, CO 80110
Ph: 1-800-525-8460, (303) 936-7432
Fax: (303)934-5581
Web: www.pelsue.com E-mail: sales@pelsue.com



Product Specifications

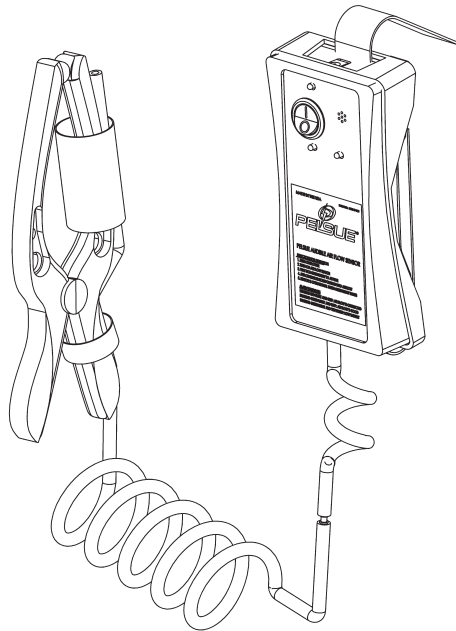

DIMETRIC VIEW

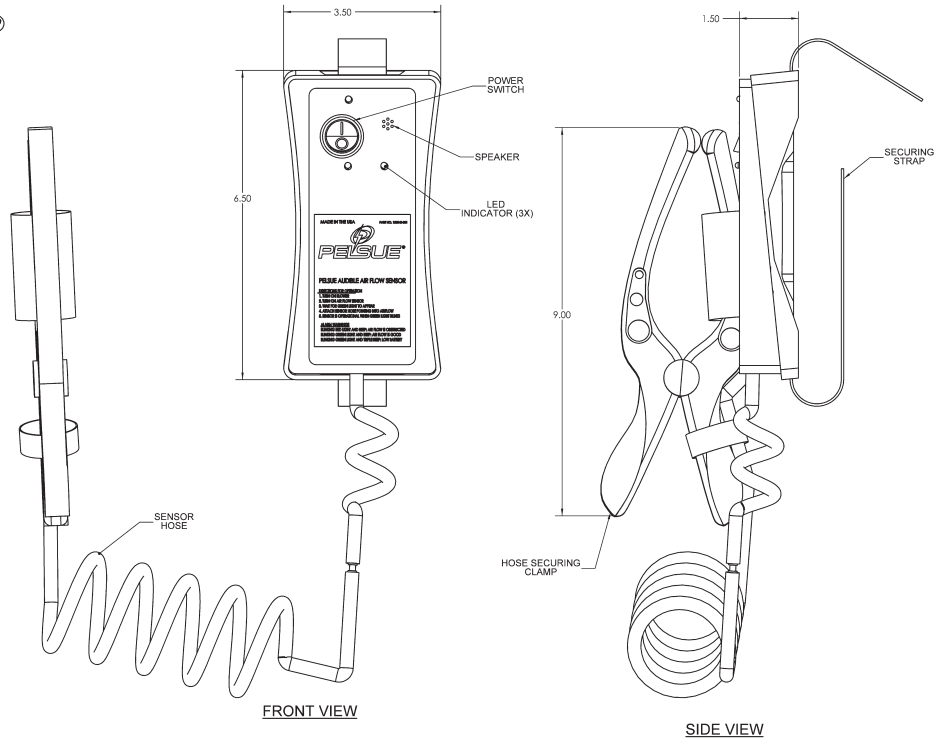

FRONT VIEW

SIDE VIEW

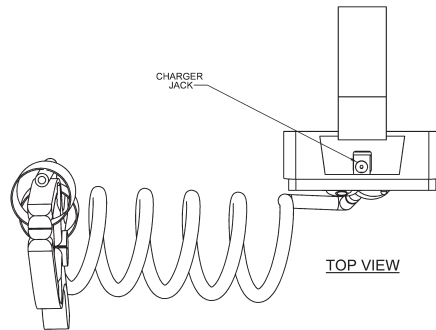

TOP VIEW

AIR FLOW ALARM ENCLOSURE

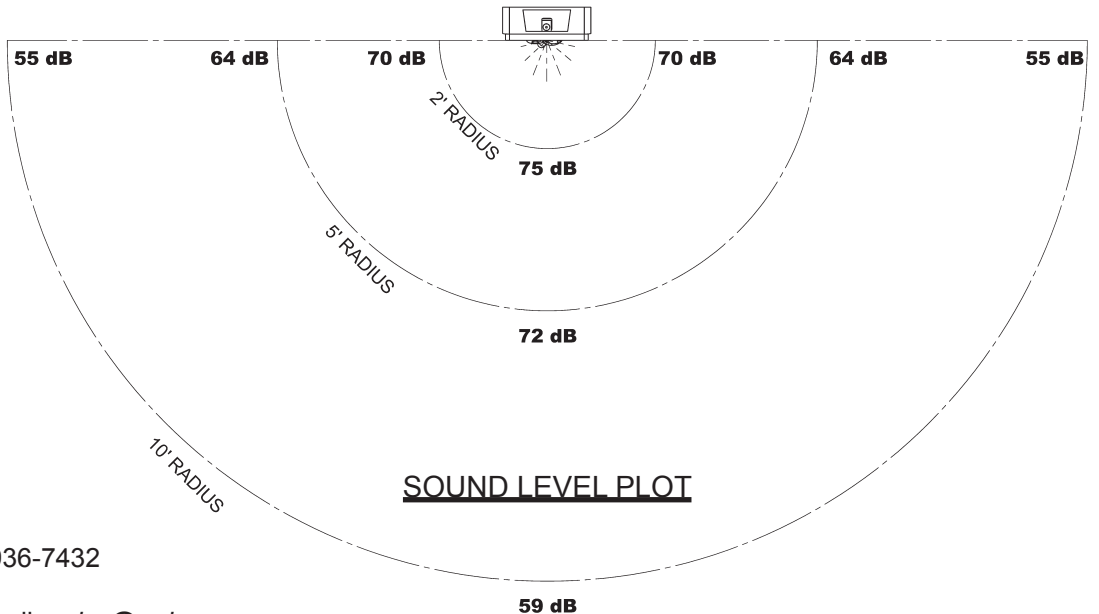

SOUND LEVEL PLOT



2500 S. Tejon St.
 Englewood, CO 80110
 Ph: 1-800-525-8460, (303) 936-7432
 Fax: (303)934-5581
 Web: www.pelsue.com E-mail: sales@pelsue.com