



# Product Specifications

## Model: Welding Gas Cylinder Cart - OSHA Compliant

The Pelsue Welding Gas Cylinder Cart is a completely mobile transport and storage cart for oxygen and fuel-gas cylinders. The Welding Cart is designed to be compliant with regards to OSHA Standard 1926.350(a)(10) & 1910.253 (b)(4)(iii) as it relates to the storage of oxygen and fuel-gas cylinders. The referenced standards require oxygen and fuel-gas cylinders to be separated by a fire-proof barrier when in storage. The Pelsue Welding Cart conforms to this standard by encasing a proprietary fire brick material within the steel fireproof barrier. The welding cart also has an integral tray for the storage and transport of any welding accessories. The welding cart will accommodate two gas cylinders and provides steel chains to retain the cylinders during transport. The welding cart is equipped with large wheels for easy rolling over rough or uneven surfaces. The welding cart is also equipped with three triangulated lifting points for the installation of a 3-point bridle in order to aid lifting of the system to a non-elevator-service location.

### General Specifications:

- OSHA-Compliant Gas Cylinder Cart for the storage & transport of oxygen & fuel-gas cylinders as per; OSHA 1926.350 & 1910.253
  - Welding Cart Includes
    - Cylinder retaining chains
    - Accessory Tray
    - 14" Diameter Wheels
    - Large Handle
    - Three Anchors for Lifting Bridle

### Materials & Construction:

- Cart
  - Structure.....Powdercoated Steel
- Hardware.....Plated Steel
- Fireproof
  - Barrier.....Insulating Fire Brick sandwiched between steel plate.

### Dimensions:

- Height**..... 61-1/2"
- Length**..... 32"
- Width** ..... 23-1/4"
- Weight**..... 82 lbs. (37.2 kg)

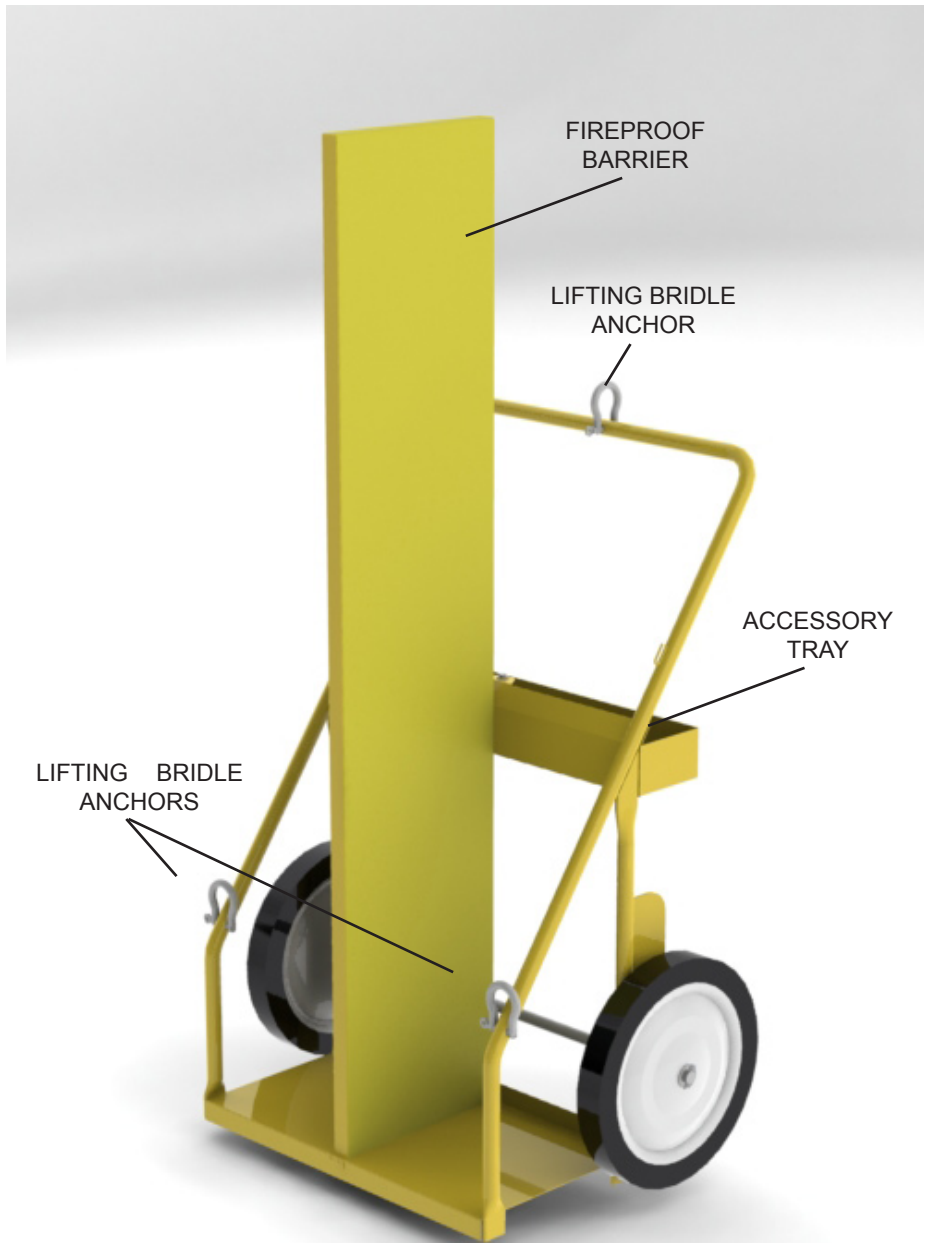

**Welding Gas Cylinder Cart**  
**Isometric View**



2500 S. Tejon St.  
Englewood, CO 80110  
Ph: 1-800-525-8460, (303) 936-7432  
Fax: (303)934-5581  
Web: [www.pelsue.com](http://www.pelsue.com) E-mail: [sales@pelsue.com](mailto:sales@pelsue.com)



# Product Specifications

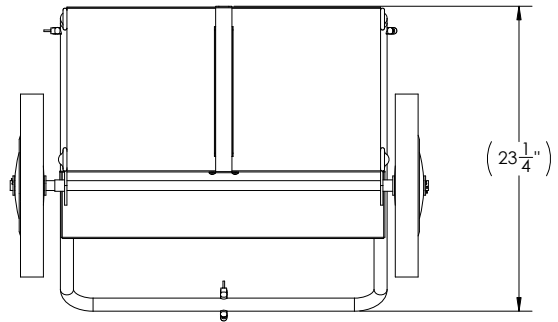

TOP VIEW

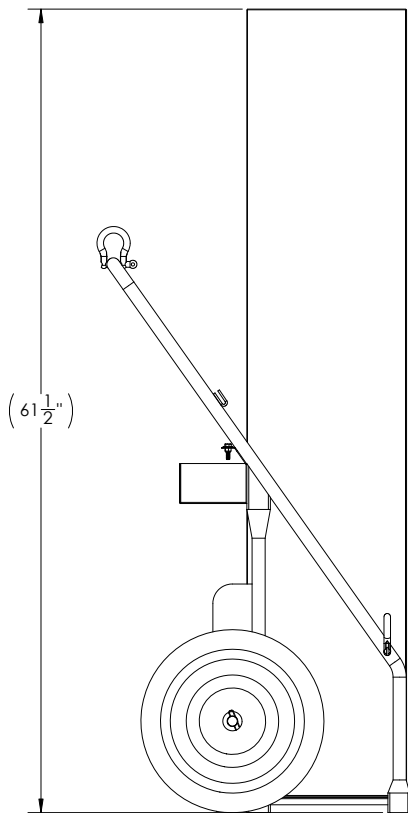

SIDE VIEW

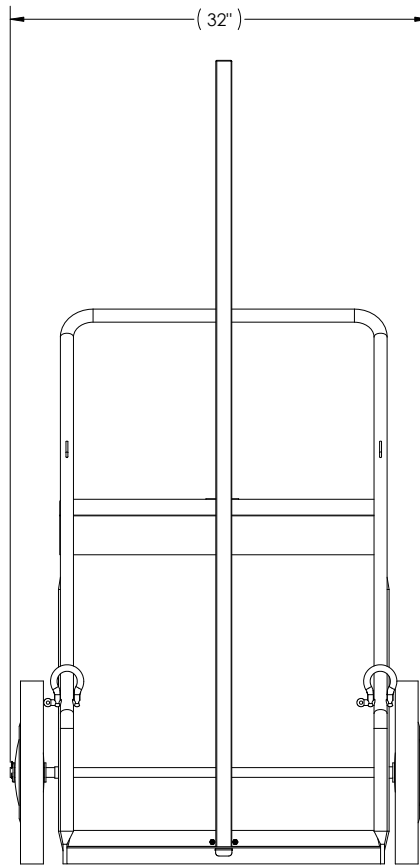

FRONT VIEW



2500 S. Tejon St.  
Englewood, CO 80110  
Ph: 1-800-525-8460, (303) 936-7432  
Fax: (303)934-5581  
Web: [www.pelsue.com](http://www.pelsue.com) E-mail: [sales@pelsue.com](mailto:sales@pelsue.com)